

REMOTE CONTROLLED DOG TRAINING COLLARS

OWNER'S MANUAL



Dogtra Company

1250 E. 223rd Street, Suite 119
Carson, CA 90745

Tel : (310) 522-1800

Fax : (310) 522-1805

Toll Free: 1-888-811-9111

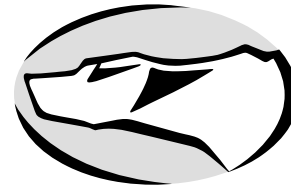

dogtra 1400NCP ***Woodgrain Finish Series***



CONTENTS

• MAIN FEATURES	2
• PRODUCT SAFETY AND HEALTH STATEMENTS	3
• dogtra COLLAR PACKAGE CONTENTS	5
• DESCRIPTION OF TRANSMITTER PARTS	6
• DESCRIPTION OF COLLAR / RECEIVER PARTS	14
• BATTERY CHARGER	19
• CHARGING THE BATTERIES	20
• TESTING YOUR dogtra 1400NCP Woodgrain Finish Series COLLAR	23
• OPERATING INSTRUCTIONS	25
• ACCESSORIES	29
• WARRANTY AND REPAIR INFORMATION	30

MAIN FEATURES

- Easy-to-use, ergonomic transmitter.
- Rheostat dial that allows for gradual increases in stimulation intensity with no jumps between levels.
- The **dogtra 1400NCP Woodgrain Finish Series** has a 1/2-mile range.
- Two-dog models allow the trainer to control two different dogs from one transmitter.
- Waterproof collar/receiver and water-resistant transmitter.
- No external antenna on the collar receiver.
- Rechargeable, user-replaceable Ni-MH batteries.
- One-charger system allows the transmitter and receiver(s) to be charged at the same time.
- Over 3000 different identity codes to prevent conflicts with other e-collars.

PRODUCT SAFETY AND HEALTH STATEMENTS

Safety for your dog

Studies conducted by animal health professionals at Dogtra Company's training facilities showed no adverse effects to the cardiovascular or nervous system of dogs from e-collar stimulation. These studies involved healthy dogs in a controlled environment.

Dogs should be in good health during any e-collar training. Dogtra e-collars are not intended for use on dogs weighing less than 12 pounds or under 6 months of age.

Skin irritation can occur from prolonged wearing of the stainless steel contact points on the training collar. Most dogs will exhibit some type of irritation (pressure necrosis) from prolonged contact of stainless steel contact points. This is why it states in your owner's manual:

Attention:

Avoid having the dog wear the collar with the contact points in the same place for more than two hours at a time. Leaving the contact points on the same spot for an extended period of time can cause skin irritation. If the dog is to wear the e-collar for long periods, occasionally reposition the collar so that the contact points are moved to a different spot on the dog's neck.

Proper e-collar use

dogtra e-collars are intended for the sole purpose of behavior modification of dogs. They are not intended for human use or use on other animals. Dogtra Company does not assume any liability for improper use of the Dogtra e-collar.

Aggressive dogs

dogtra does not recommend using the e-collar to correct dogs that are aggressive towards other dogs or people. In many such cases the dog will associate the stimulation with the other dog or individual and become even more aggressive. Dog aggression is best treated by a dog training specialist.

Interference with other electronic devices

Dogtra's industry-leading technology filtering system ensures minimal interference with other electronic devices (cellular phones, security systems, etc.). Our digital microprocessor offers thousands of unique codes to eliminate frequency match-up with other Dogtra e-collars.

Inadvertent activation

If the constant button is held down for 12 seconds or more the unit will automatically shut down. It will reactivate when the button is released.

***dogtra* COLLAR
PACKAGE CONTENTS**

- Transmitter
- Receiver (two collar receivers for *dogtra* two-dog models)
- Battery charger and splitter cable
- Test light
- Owner's manual

DESCRIPTION OF TRANSMITTER PARTS

dogtra 1402NCP Woodgrain Finish transmitter

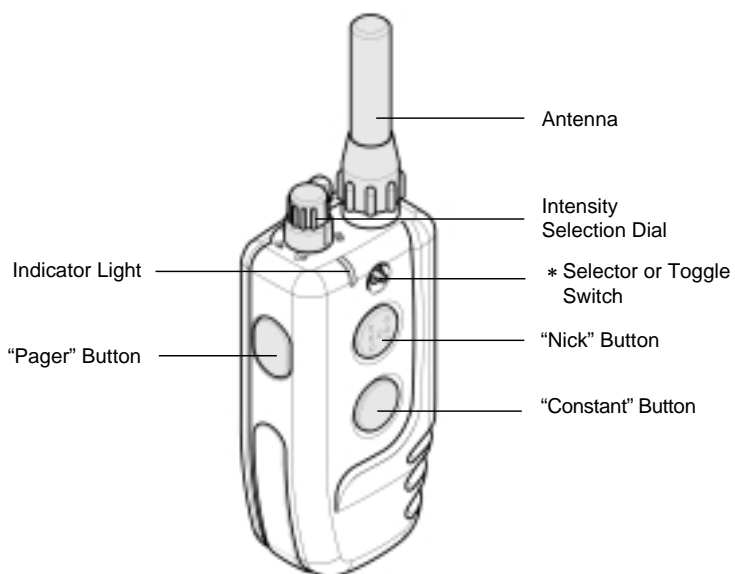

**indicates optional switch for 2-dog models*

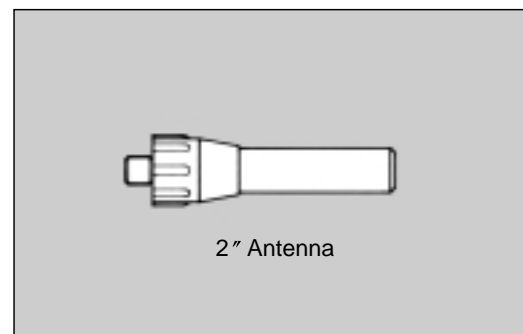

Transmitter Antenna

A short 2" antenna is supplied with the *dogtra* 1400NCP Woodgrain Finish Series transmitter.

The antenna should be screwed into the top of the transmitter to ensure that the signals are sent properly to the collar receiver and that maximum range is attained.

***dogtra*1402NCP Woodgrain Finish TWO-DOG MODELS**

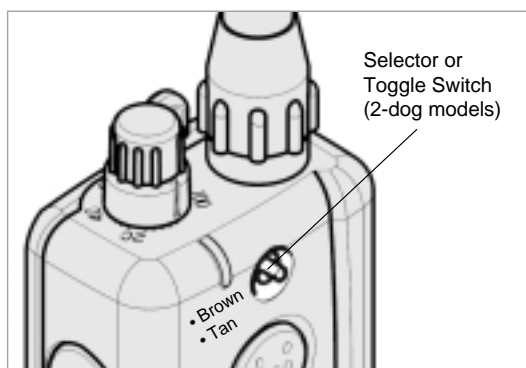

Selector or Toggle Switch on the *dogtra*1402NCP Woodgrain Finish Two-Dog Models

The two-dog models have a toggle switch on the face of the transmitter located above the “Nick” button. The toggle switch allows for selection of either collar.

Set the toggle switch on the brown position to select the brown collar and the tan position to select the tan collar.

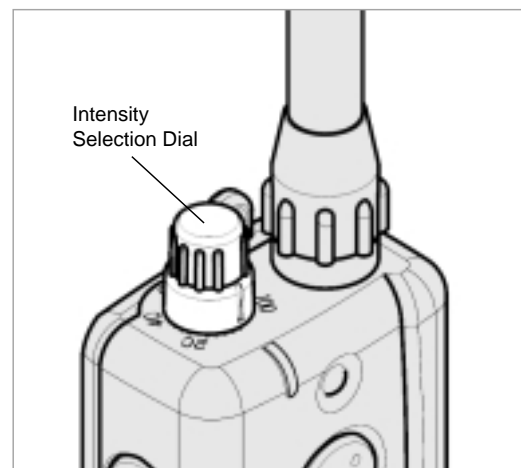

Intensity Selection Dial

The intensity selection dial is located on the top of the transmitter: (0) being the lowest level and (100) being the highest.

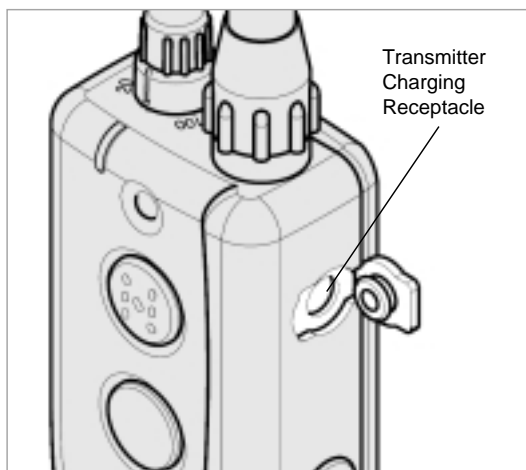

Transmitter Battery Charging Receptacle

Located on the side of the transmitter, the receptacle is covered by a rubber plug. Insert one end of the battery charging cable into the receptacle to charge the battery. (See Battery Charging Procedure on page 22.)

After charging is completed, close the receptacle with its rubber plug to make sure dirt or water does not get inside.

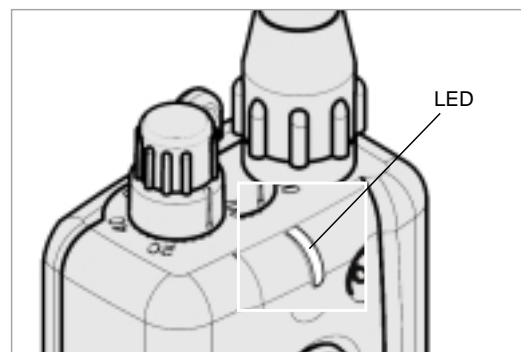

Transmitter Indicator Light (LED window)

The transmitter indicator light is located near the intensity selection dial. When a button on the transmitter is pushed, the light comes on to indicate that the transmitter is being activated. The color of the light indicates the status of battery life. The LED glows green when the battery is fully charged and turns to amber when battery life is getting low. When the LED emits a blinking red light, the battery needs to be recharged.

green = full charge, **amber** = medium charge
red = needs charge

BUTTON FUNCTION

dogtra 1400NCP Woodgrain Finish

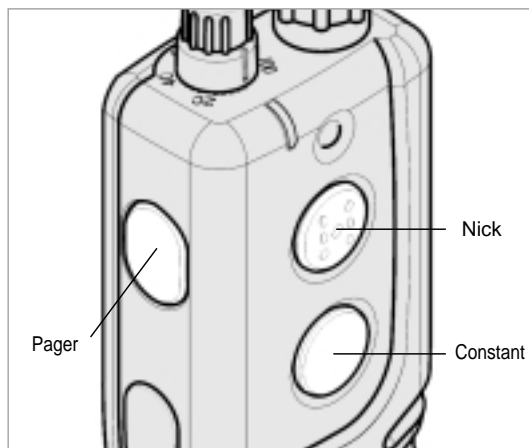

The transmitter for *dogtra* 1400NCP Woodgrain Finish Series has three buttons (two on the face of the transmitter and one on the side).

“Nick” Button

When the “Nick” button is pushed the receiver emits a single, rapid pulse of electrical stimulation.

“Constant” Button

Pressing the “Constant” button gives continuous stimulation as long as the button is pushed, for up to twelve seconds. If the button is not released after twelve seconds, the stimulation will automatically turn off as a safety feature. The collar will be ready to be reactivated once the button has been released.

“Pager” Button

Pressing the “Pager” button on the side of the transmitter causes the collar to vibrate. This is a great way of communicating with your dog using non-electrical stimulation.

DESCRIPTION OF COLLAR / RECEIVER PARTS

dogtra 1400NCP Woodgrain Finish Series collar

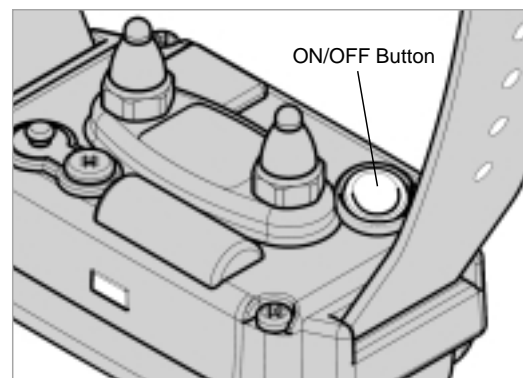
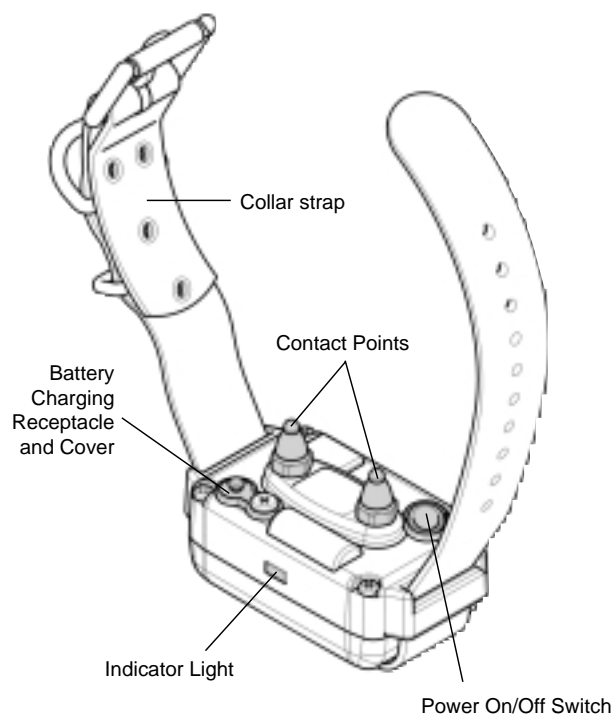

Turning on the Collar Receiver

The ON/OFF button is on the bottom of the receivers. Push and hold the button for two seconds until the LED light, located on the front of the collar, starts blinking. The indicator light will blink once every 2 seconds after the color is turned on. The color of the light indicates the status of battery life. The LED glows green when the battery is fully charged and turns to amber when battery life is getting low. When the LED emits a blinking red light, the battery needs to be recharged.

green = full charge, **amber** = medium charge
red = needs charge

When the “Constant” button on the transmitter is pushed, the collar indicator light will glow steadily as long as you hold the button down, for up to twelve seconds. When the “Nick” button is pushed, the light comes on for a fraction of a second.

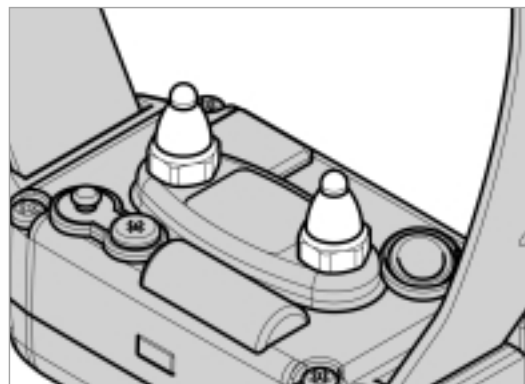

Fitting the Collar on the Dog

The collar should be fitted so that the stainless steel contact points press firmly against the dog’s skin.

A loose fit can allow the collar to move around on the dog’s neck. When this happens the contact points may rub the skin and cause irritation. If the collar is too loose, electrical contact will be inconsistent and your corrections will be inconsistent also.

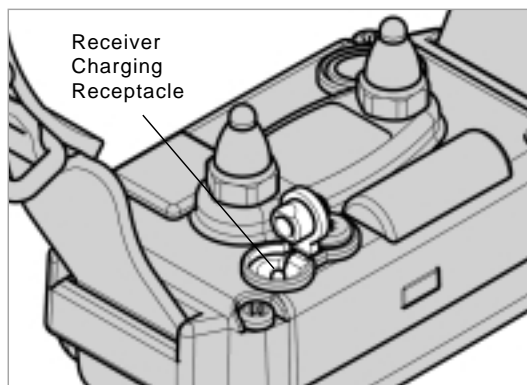

Receiver Battery Charging Receptacle

On the inside of the collar receiver, next to the collar strap, is a battery charging receptacle with a rubber cover plug.

Internal Antenna

The **dogtra 1400NCP Woodgrain Finish Series** has a non-exposed antenna that is located inside the collar receiver.

BATTERY CHARGER

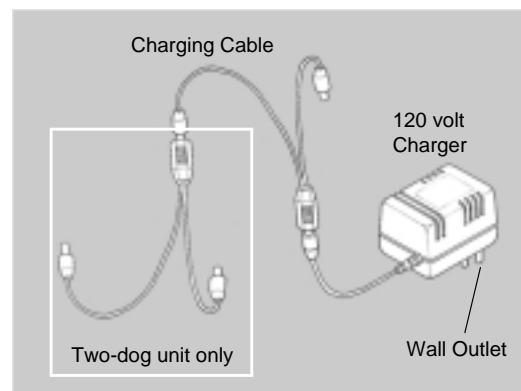

The battery charger and charging cables allow you to charge both the transmitter and receiver at the same time. The battery charger is designed for a 120-volt wall outlet. (European 230-volt AC chargers and 12-volt field charger for your automobile are also available.)

To use the battery charger for the two-dog unit, combine both sets of battery charging (splitter) cables as shown. This enables you to charge the transmitter and both receivers at the same time.

CHARGING THE BATTERIES

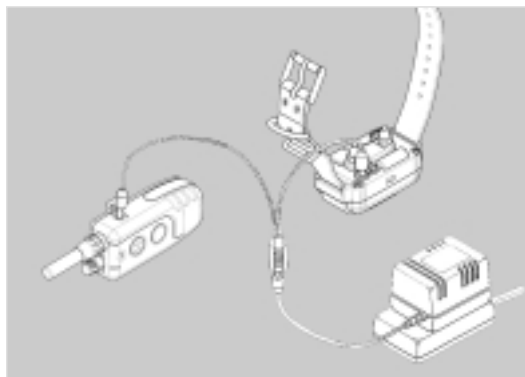

dogtra uses Ni-MH (Nickel-Metal-Hydride) batteries that do not set a memory and can be charged on a regular basis without harm to the battery. There is no need to completely drain the batteries between charges. However, doing so will help to extend the overall lifetime of the batteries.

1. Charge the batteries for 14 hours before using the collar for the first time.

2. Do not charge the batteries near any flammable substances.
3. Fully charge the batteries for 14 hours if the collar is to be stored without use for a period of a month or more.
4. Recharge the battery if :
 - the indicator light on the collar is emitting a red color
 - the indicator light on the transmitter or receiver will not come on
 - the indicator light on the transmitter or receiver comes on momentarily but will not stay on when the “Constant” button is pushed.

Battery Charging Procedure

1. Attach the charging cables to both the transmitter and receiver(s), as shown on page 20.
2. Plug the charger into a 120-volt wall outlet or, if using the accessory field charger, plug into a cigarette lighter. (Use a 230-volt European charger for Europe.) When properly plugged in, all indicator lights should glow red.

The receiver automatically turns off when you insert the charging cable into the battery-charging receptacle on the receiver.

3. After charging, cover the battery charging receptacles with the rubber plugs on the transmitter and receiver.
4. The battery is fully charged with a 14-hour charge. The lights will stay red during the charging process. They DO NOT turn green when fully charged. Charging the batteries for more than 14 hours at one time will not extend battery life.

TESTING YOUR *dogtra* 1400NCP Woodgrain Finish Series COLLAR

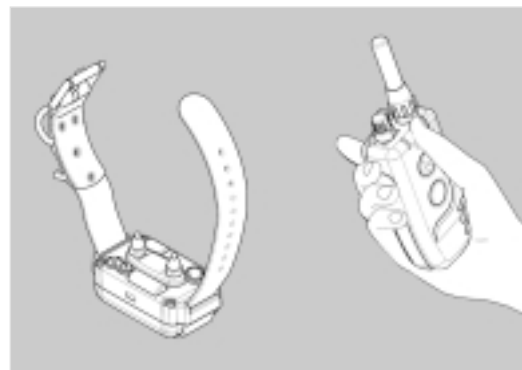

1. Turn the collar on by pressing the button on the back side of the collar receiver. The indicator light will come on for a moment then blink once every two seconds, showing that the collar is ready to use. (If the indicator light is red, the batteries need to be charged.) Place the test light on the contact points of receiver and hold it there.

2. Watch the test light as you push the “Nick” button on the transmitter. It should light for just a moment.
3. Watch the test light as you push the “Constant” button on the transmitter. It should glow brightly. As a safety feature, the collar receiver will automatically shut off stimulation if the constant button is depressed for twelve seconds or longer.
4. Change the intensity dial on the transmitter clockwise and then counterclockwise. The test light should glow brighter with higher levels of stimulation and dimmer with lower levels.

NOTE : It is normal for the test light not to come on if the intensity level is set below level ten.

5. Pressing the “Pager” button on the side of the transmitter causes the collar to vibrate for up to twelve seconds. The collar will reactivate when you push the button again.

OPERATING INSTRUCTIONS

Fitting the Collar

The collar strap should be adjusted so that the contact points are held firmly against the dog’s skin. If the collar is too loose, irritation may result from the contact points rubbing against the skin.

If the dog has a heavy coat, move the receiver up and down to work the contact points down into the coat.

ATTENTION!

Avoid having the dog wear the collar with the contact points in the same place for more than two hours at a time. Leaving the points on the same spot for extended periods of time can cause skin irritation. If the dog is to wear the e-collar for long periods, occasionally reposition the collar so that the contact points are moved to a different spot on the dog’s neck.

Intensity Selection

To select the intensity level, start on the zero (0) setting. Gradually increase the level until you get a response from the dog that would be equivalent to a quick pull or jerk with a leash.

Remember that you will need to adjust the setting (upward or downward) as the dog's attitude changes, especially during times of increased excitement or distraction.

Prolonged use of the Pager (12 seconds or longer) will drain the batteries more quickly.

Maintenance

The receiver and collar strap should be cleaned periodically with detergent and water to prevent malfunction.

Always clean and rinse the collar thoroughly with tap water after use in salt water. Be sure the charging receptacle is completely dry before inserting the battery charger into the transmitter or receiver.

Reception

The **dogtra 1400NCP Woodgrain Finish Series** collar has a half-mile range. Depending on the way you use your transmitter, the transmitting range may vary. Hold the transmitter away from your body and avoid touching the antenna to get the greatest range.



Maximum Range



Typical Range



Minimum Range

If your finger touches the antenna near the dial on the top of the transmitter, the actual range may be reduced. Additional environmental factors may also affect the range of your unit.

ACCESSORIES

The following items may be purchased separately:

European Charger

Designed for use with 230V AC electrical outlets in Europe.

Field Auto Charger

Designed for use with the 12-volt cigarette lighter in your car.

WARRANTY AND REPAIR INFORMATION

Dogtra Company provides the original purchaser a **LIMITED LIFETIME WARRANTY** for the 1400NCP Woodgrain Finish Series on parts (excluding batteries) from the date of the original purchase. Labor is covered for two years after purchase. Once the labor warranty has expired, all repairs will incur a variable labor charge depending on the extent of work required.

To Qualify for the Limited Lifetime Warranty:

The limited lifetime warranty applies to units purchased after Dec. 31, 2005. Fill out the warranty registration card that came with your Dogtra unit and mail it in along with a copy of your receipt within 30 days of purchase. Or, you can register your product online at www.dogtra.com.

Not Covered Under Warranty:

If product registration is not completed within 30 days of purchase and/or the product is resold, the warranty will become void and all repairs will be subject to applicable labor fees.

Dogtra DOES NOT replace defective units or provide refunds after 30 days from date of purchase.

Dogtra's warranty DOES NOT cover repairs or replacement due to misuse, improper maintenance or lost units. Any water damage on models that are not waterproof will not be covered. All replacement costs for either the transmitter or receiver is the owner's responsibility.

The Limited Lifetime Warranty will expire (5) years from the date a unit is discontinued in production by Dogtra Company.

* Batteries, or the labor to replace them, are NOT covered under the warranty after the first year.

The warranty is void if the unit has been altered or an unauthorized person has attempted repair work.

Procedure for Repair Work:

Return shipping for warranty work is the owner's responsibility. The cost for shipping (via regular ground service) back to the customer is covered by Dogtra Co. within the continental United States. Any expedited shipping service will be at the owner's expense. Dogtra is not responsible for loss of training time or inconvenience while the unit is in our warehouse for repair work. Dogtra does not provide loaner units or any form of compensation during the repair period.

A copy of the sales receipt showing purchase date is required before warranty work is begun.

Write a note briefly explaining the problem and include your name, address, city/state/zip code, daytime phone number and evening phone

number. Or, you can visit our web site at www.dogtra.com to fill out a Service Request Form. If repair costs are not covered under warranty, we will call you for credit card information once the work has been completed. For any questions concerning your Dogtra products call us Toll Free at 1-888-811-9111, Pacific Time.

Send repair units to:

Dogtra Company

1250 E. 223rd Street, Suite 119
Carson, CA 90745